

PART#: CAI-75-5147



PRINT

Vehicle Application

YEAR: 2018+

MAKE: Ford

MODEL: Mustang GT

ENGINE: 5.0L V8

Note:

This intake kit may not fit with the following Aftermarket Parts installed:

- Body Lift or Lowering Kit
- Custom Hood
- Throttle Body Spacer / Upgrade

Tools Required

- Socket Wrench
- 7mm, 10mm, 15mm Socket
- Adjustable Wrench
- Socket Extension
- Pliers
- Bolt Cutters
- 5/16" Socket / Nut Driver
- T20 Torx
- Phillips Head Screwdriver
- Panel Popper / Flat Blade Screwdriver

Note: Approximate Install Time: 30 Mins.

S&B Filter Maintenance

KF-1057 (<https://www.sbfilters.com/replacement-filters/filters-sb-intakes/kf-1057>) Cotton Cleanable : If the enclosed filter is RED, it came pre-oiled from the factory.

Click here (<https://www.sbfilters.com/replacement-filters/filters-sb-intakes/kf-1057>) for exact oil amount required for cleaning.



KF-1057D (https://www.sbfilters.com/replacement-filters/filters-sb-intakes/kf-1057?variant_id=224) Dry Extendable : If the enclosed filters is WHITE, it is a disposable filter and should be discarded once it reaches capacity. This filter does not require oil.

Before You Start

- Please read the entire product guide before proceeding.
- Ensure all parts are present.
- If you are missing any of the components, call our customer support at (909) 947-0015.
- Do not work on your vehicle while the engine is hot.
- Make sure the engine is turned off and the vehicle is in Park or the Parking Brake is set.

Related Products

- Cotton Cleanable Filter ([KF-1057 \(https://www.sbfilters.com/replacement-filters/filters-sb-intakes/kf-1057?variant_id=223\)](https://www.sbfilters.com/replacement-filters/filters-sb-intakes/kf-1057?variant_id=223))
- Dry Extendable Filter ([KF-1057D \(https://www.sbfilters.com/replacement-filters/filters-sb-intakes/kf-1057?variant_id=224\)](https://www.sbfilters.com/replacement-filters/filters-sb-intakes/kf-1057?variant_id=224))
- Cleaning & Oiling Kit (88-0008 (<https://www.sbfilters.com/cleaning-kits/precision-ii-cleaning-oil-kit>))
- Filter Wrap (WF-1057 (<https://www.sbfilters.com/filter-wraps/wf-1057>))

Performance Testing

- After your installation is complete engage parking brake and start your engine. Listen for abnormal noises. If an air leak is detected, re-inspect hoses and connections as they may need to be repositioned and tightened
- S&B FILTERS recommends that you keep your OE intake system in the event it is required in the future.
- In order to maintain your warranty, all connections and components must be checked periodically for alignment and for proper tension on all connections. Failure to do so may void your warranty.

- Use only S&B FILTERS cleaning and oil products to service your filter. Using any other brand oil and or cleaners on your S&B air filter may void your warranty.

Warning!

If your vehicle has a Vehicle Emission Control Information decal affixed to the factory airbox, a new replacement label must be obtained and installed in a readily visible position in the engine compartment in order to remain CARB compliant. Failure to do so will prevent the vehicle from passing a smog check. Replacement labels can be ordered from your local dealership. Regulations state that the VEI label shall not be affixed to any equipment which is easily detached from the vehicle. Label placement, under the hood on a painted surface is recommended.

Emission Standard

The California Air Resource Board (CARB) requires that an E.O. identification label be applied to the vehicle in order to pass a smog check inspection when a Performance Intake Kit has been installed. You must place the E.O. label provided on or near the intake kit after installation so that a smog check technician can easily verify the E.O. number. Check the status of the exemption process by looking up a specific part number at www.sbfilters.com. The CARB Exemption number and/or status is listed under the Product Details section for each part number. If the status shows as "Pending," CARB has yet to issue an exemption. Products that have not been issued an EO number are street legal in most states, but may not be used on emission controlled vehicles in the state of California and are for off-road use only. If you purchased your kit from S&B Filters directly, we will automatically mail you your Exemption Sticker when it is issued to us. If you purchased your kit from an authorized S&B Filters Dealer, log onto our web site and register to receive your Exemption Sticker.

EXPLODED VIEW

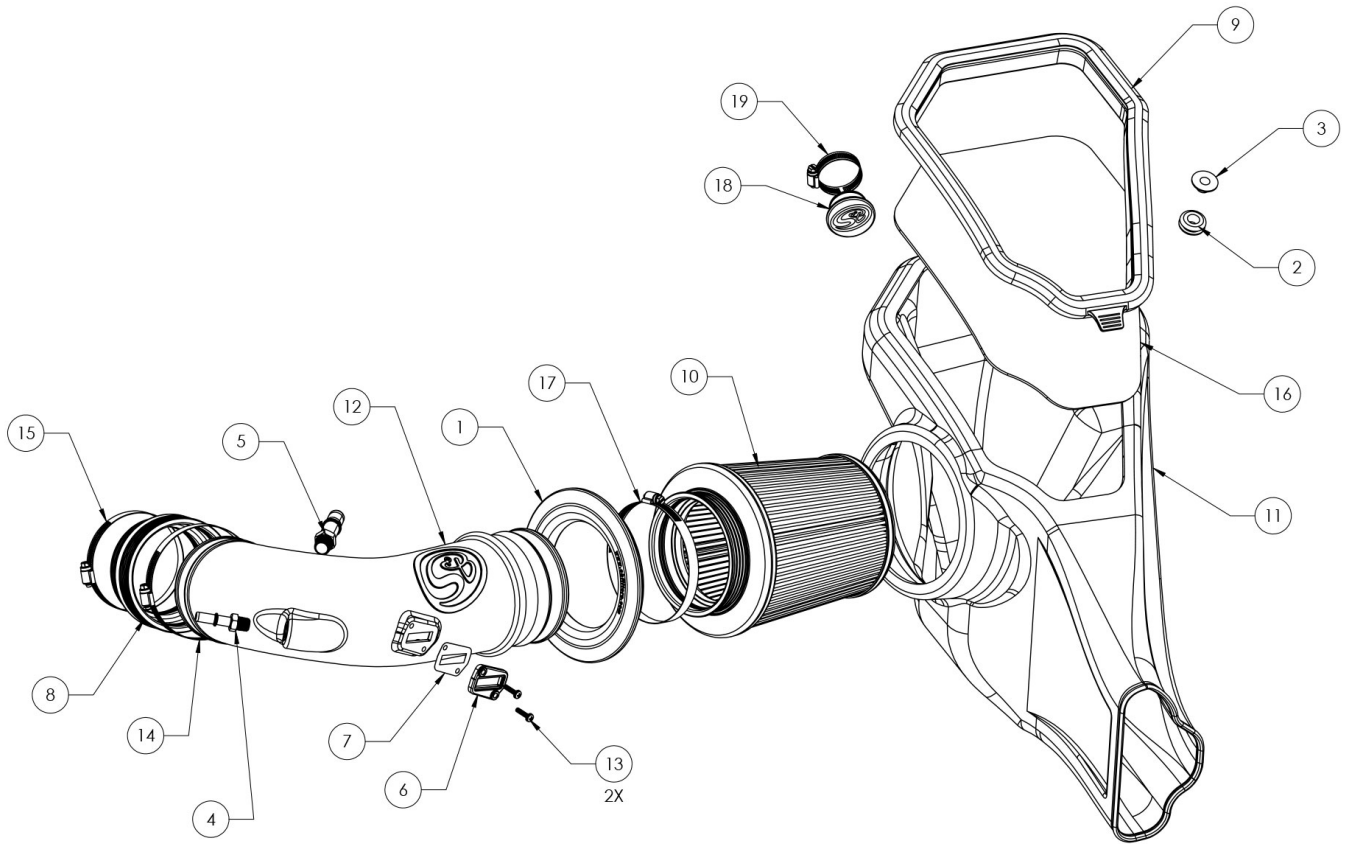

ITEM NO.	PART NUMBER	DESCRIPTION	QTY.	ITEM NO.	PART NUMBER	DESCRIPTION	QTY.
1	AI1650C-00	SILICONE TUBE SEAL	1	11	AL1378B-00	AIR BOX	1
2	AI1563-00	AIR BOX GROMMET	1	12	AL1377-00	INTAKE TUBE	1
3	AI2296-00	MACHINED SHOULDER WASHER	1	13	AI1837-00	8-32 THREAD SIZE, 3/4" LONG SCREW	2
4	AI1776-00	FITTING, QUICK CONNECT TO 1/4 NPT	1	14	AG1018-00	HOSE CLAMP, #64	1
5	AI1701-00	FITTING, QUICK CONNECT TO 3/8 NPT	1	15	AG1008-00	HOSE CLAMP, #60	1
6	AI1822-00	MAF ADAPTER PAD	1	16	AI2553-00	AIR BOX LID	1
7	AI1823-00	MAF PAD GASKET	1	17	AG1010-00	HOSE CLAMP, #80	1
8	AI1665C-00	SILICONE COUPLER	1	18	AI2554-00	SOUND TUBE DELETE PLUG	1
9	AI2552C-00	SILICONE LID SEAL	1	19	AG1016-00	Hose Clamp, #24	1
10	KF-1057	AIR FILTER	1				

INSTALLATION STEPS



STEP 1

Disconnect the positive battery cable from the threaded stud by popping up the brown zip tie connector.

Tools Required: Panel popper or Flat blade screwdriver.

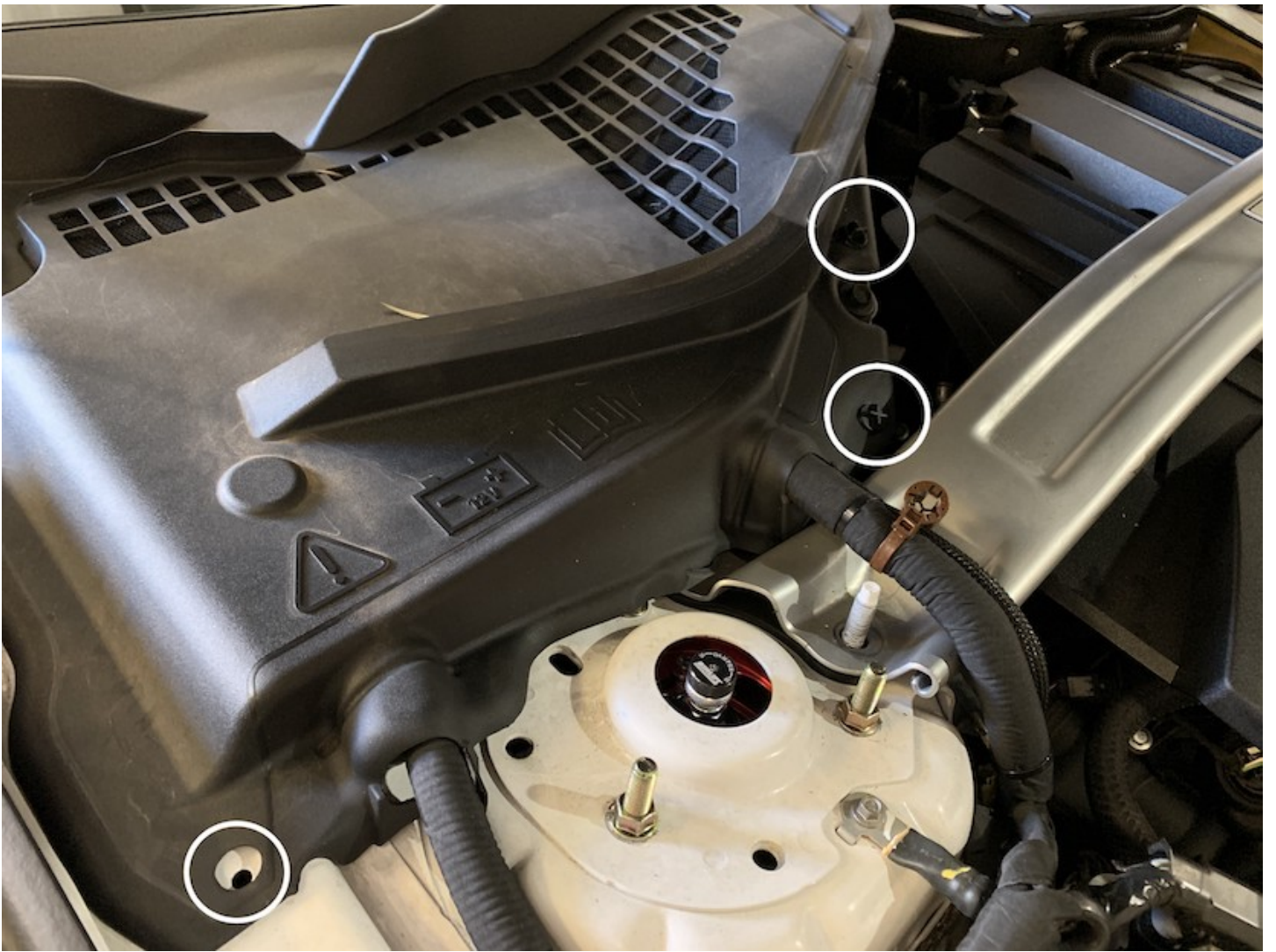

STEP 2

Remove the battery cover from the vehicle by removing the twist on panel screws in the 3 locations shown. To remove each screw, rotate the heads counter clockwise for a few rotations and then lift up.

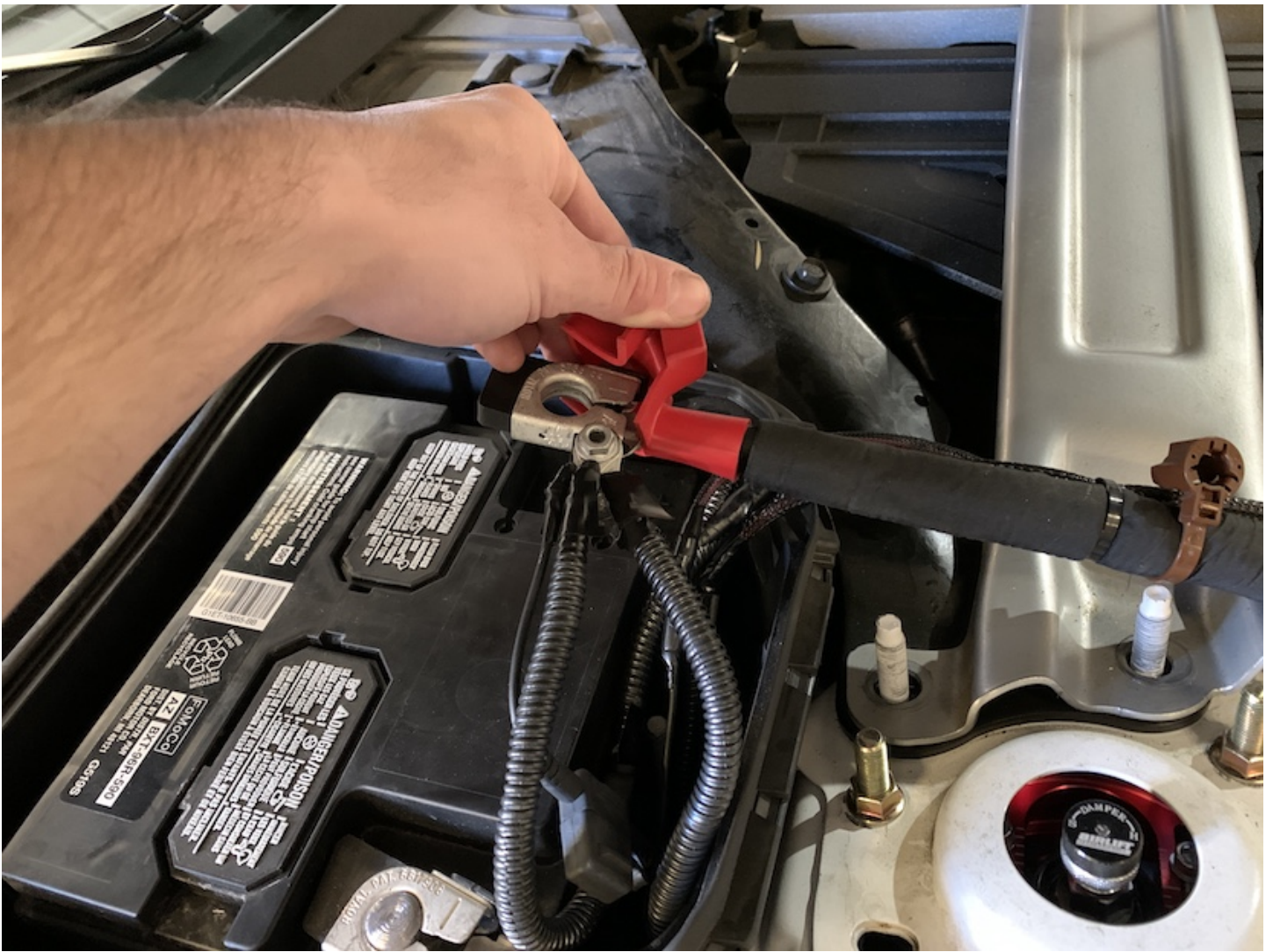

STEP 3

With the ignition switched off and the parking brake set, disconnect the Positive battery harness on the battery. The battery must be disconnected for at least 2 hours to ensure proper functionality of the kit during use. Be sure to cover the end of the harness for the rest of the installation process so that it does not touch any part of the vehicle that acts as a ground point.

Note: Failure to disconnect the battery may cause the CEL to illuminate upon completion of the installation and subsequent operation. **Do not skip this step!**

Tools Required: Socket wrench, 10mm Socket.



STEP 4

Remove the 4 nuts securing the strut tower brace to the engine bay. Then remove the strut tower brace by lifting up, avoiding the positive battery harness.

Tools Required: Socket wrench, 15mm Socket



STEP 5

Remove the two covers shown and unscrew the nuts found below them to prepare for the removal of the engine cover. Lift up on the engine cover, popping it off of the top of the engine to gain access to the entire intake system.

Tools Required: Socket wrench, 10mm Socket, Socket extension



STEP 5
IMAGE 2

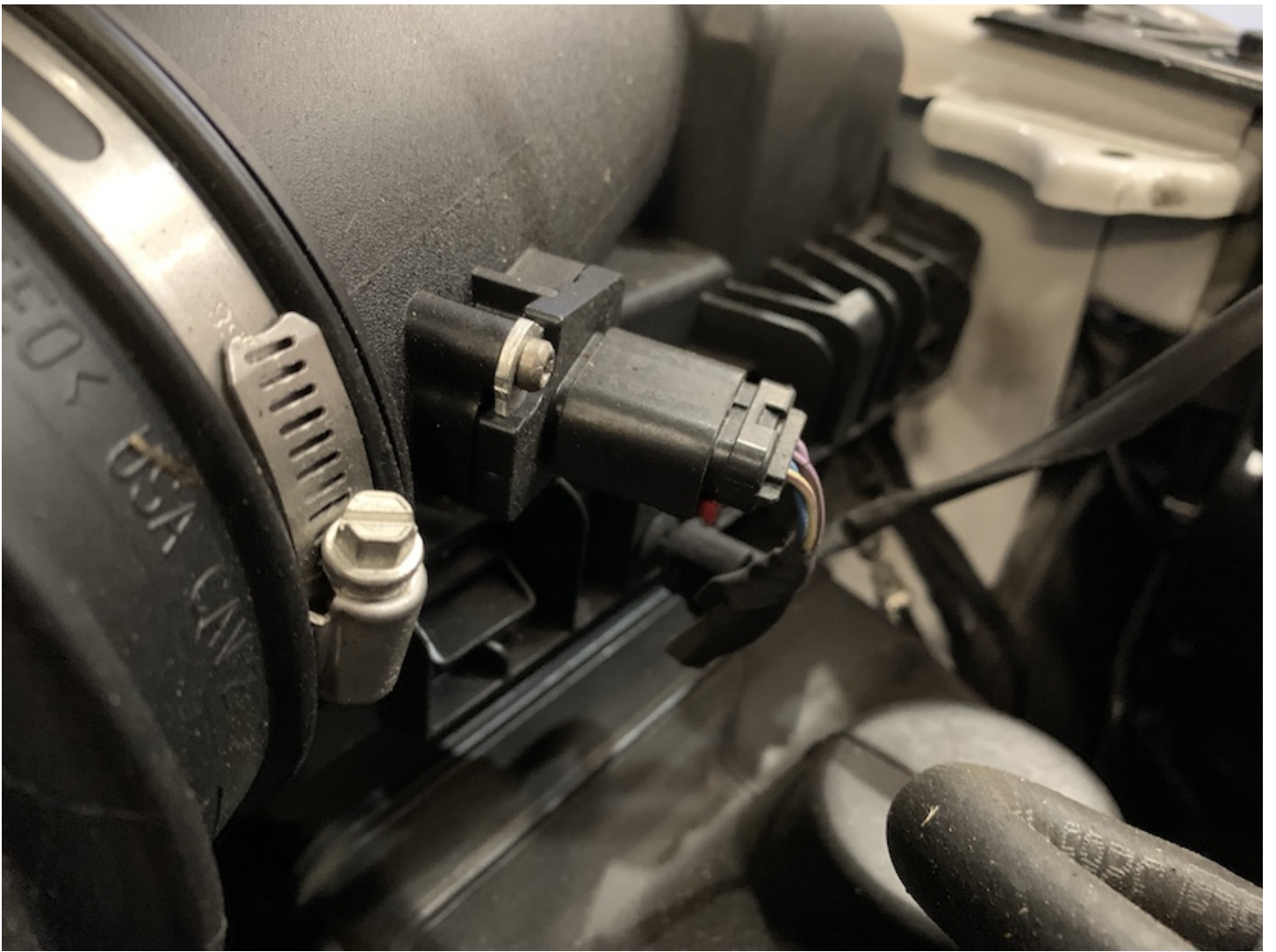

STEP 6

Pull out and push down on the red locking tab to disconnect the MAF sensor harness from the MAF sensor.

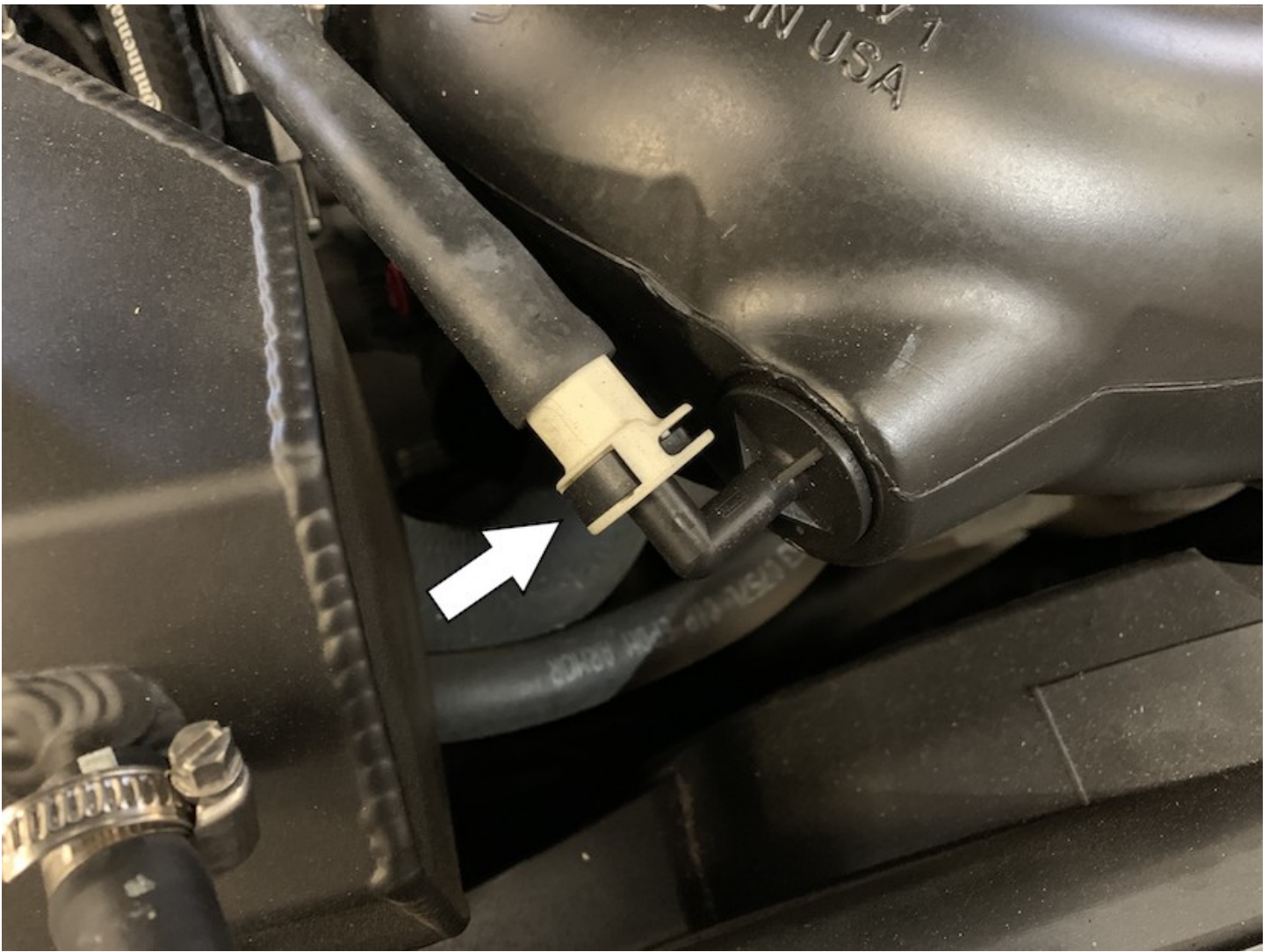

STEP 7

Disconnect the vacuum hose from the stock intake tube by pushing the indicated tab in and pulling out.

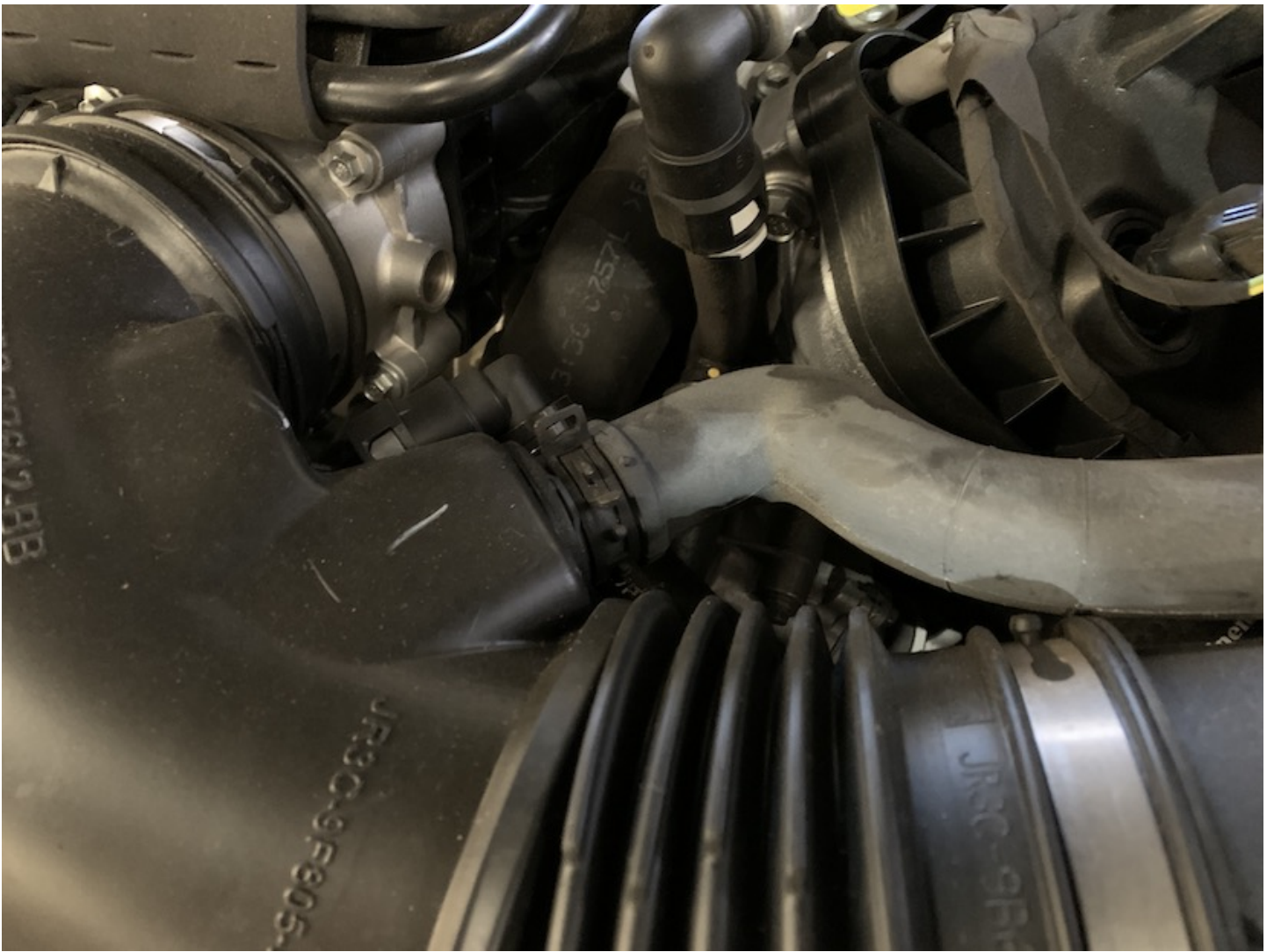

STEP 8

Disconnect the cabin sound tube from the stock intake tube by squeezing the clamp with pliers and pulling out.

Tools Required: Pliers.

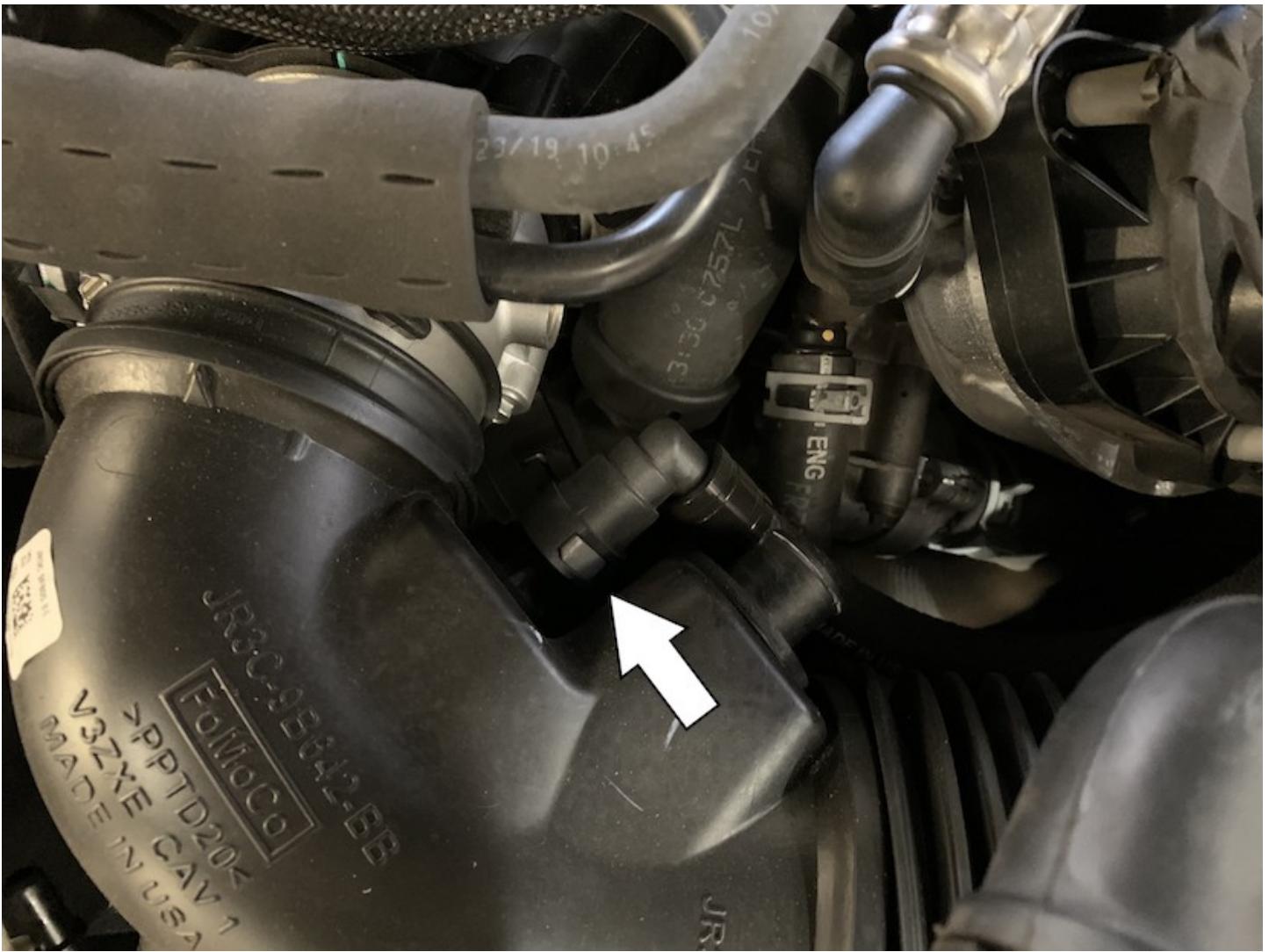

STEP 9

Disconnect the PCV hose from the stock intake tube by pressing in the indicated tab and pulling out.

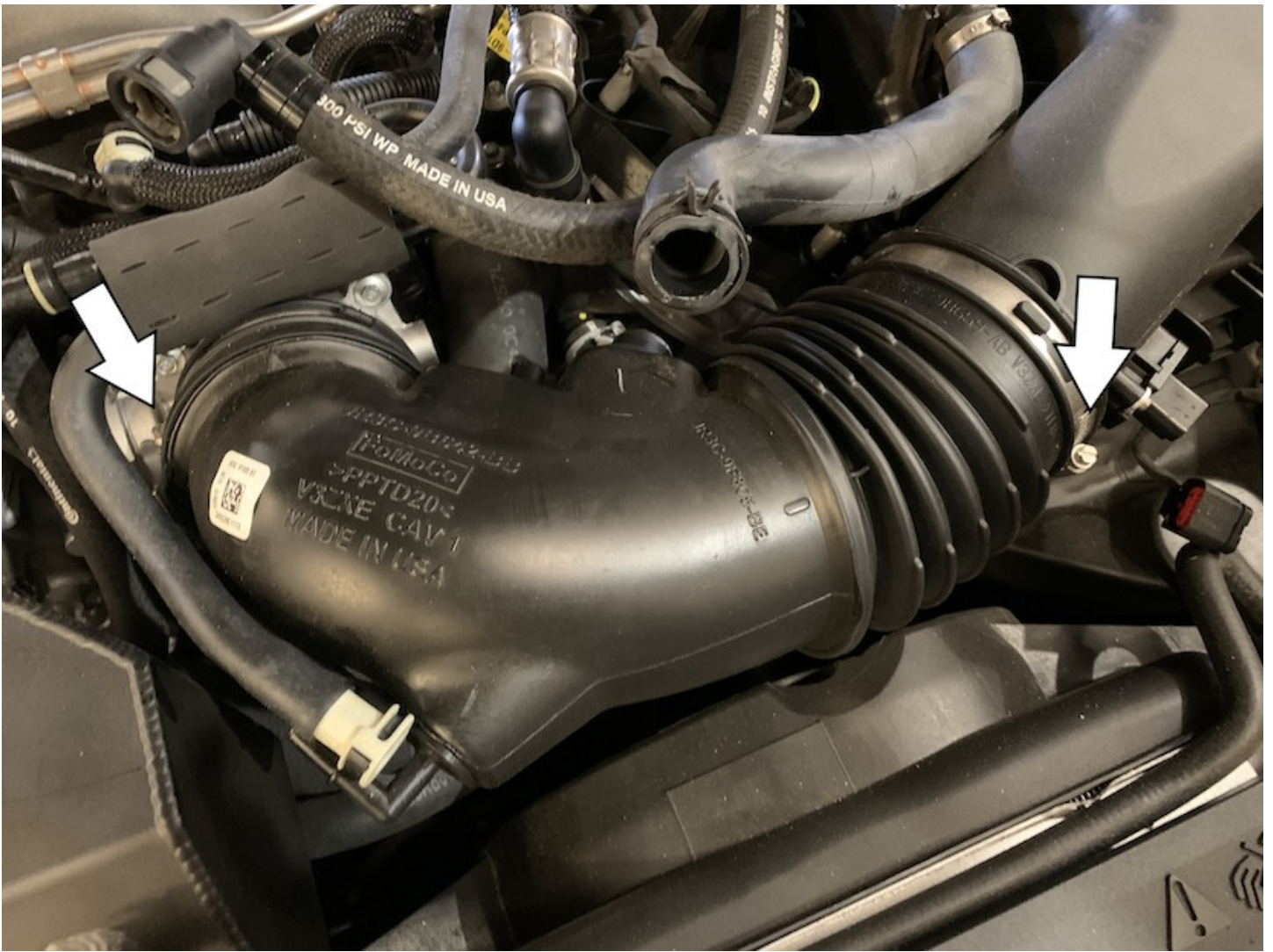

STEP 10

Loosen the hose clamps found on both ends of the stock intake tube. Remove the tube from the vehicle.

Tools Required: Socket wrench, 7mm Socket.

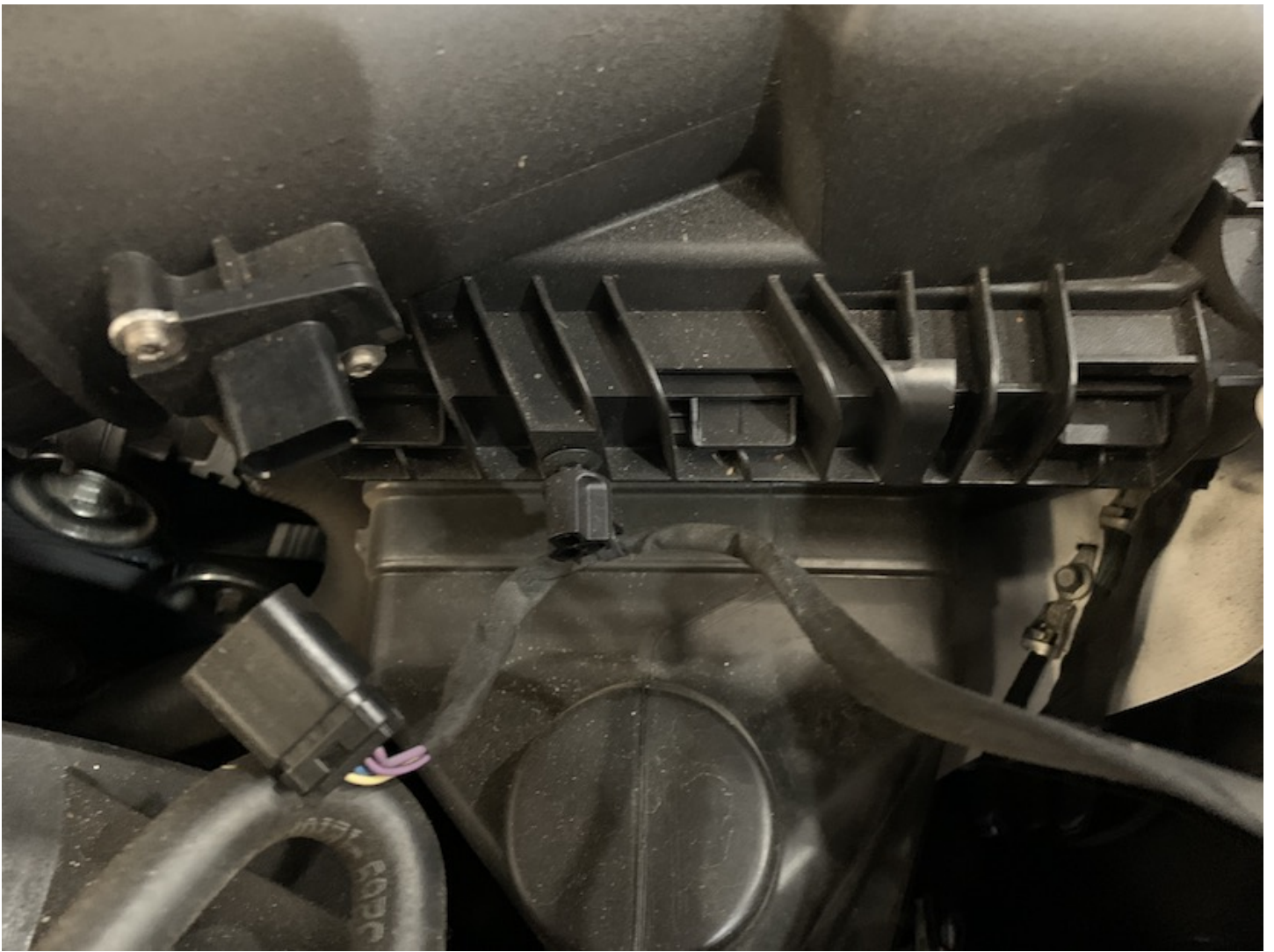

STEP 11

Pop off the MAF harness from it's mounting points on the stock intake box and vehicle frame.

Tools Required: Panel popper or flat blade screwdriver.

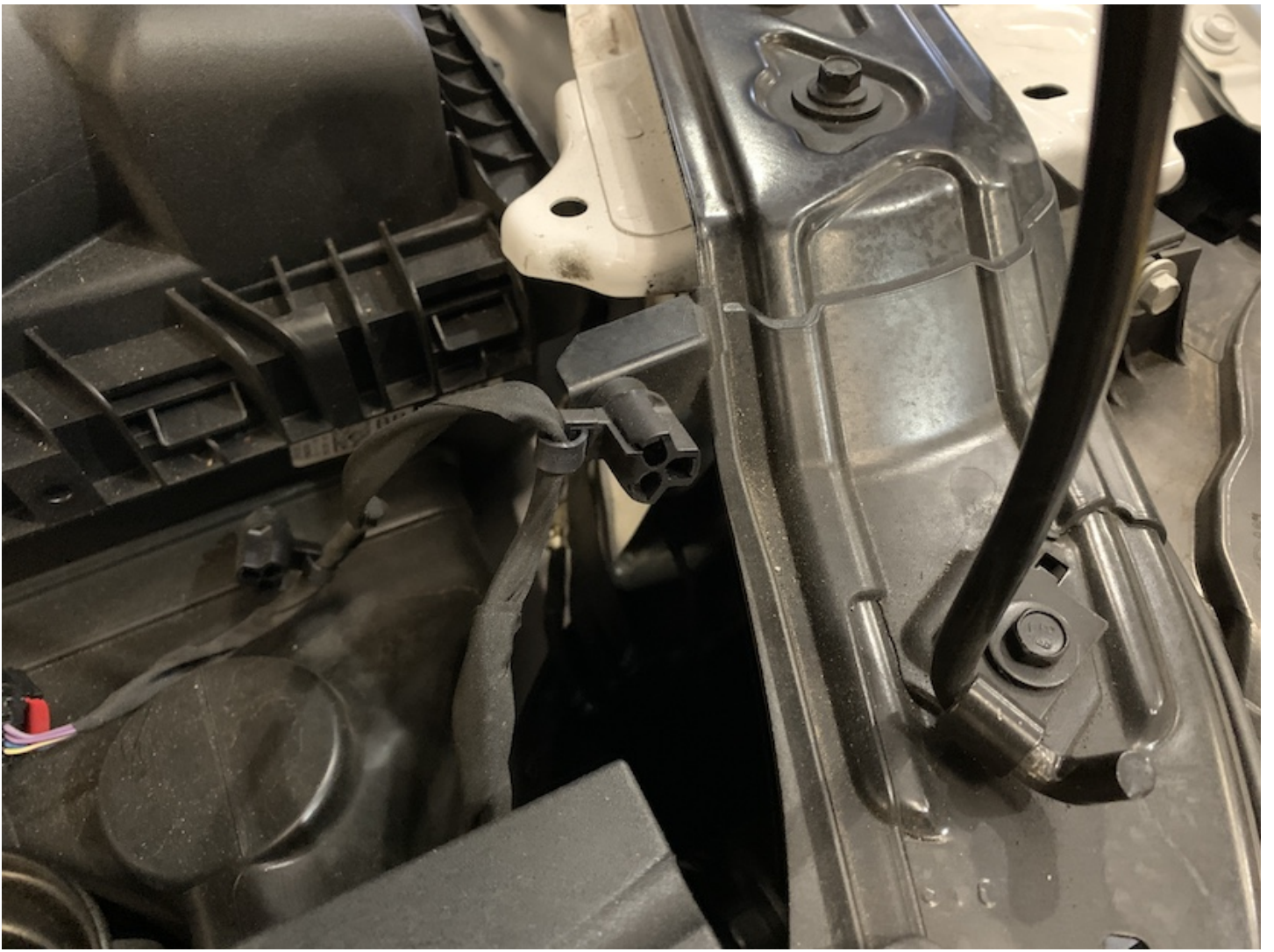

STEP 11
IMAGE 2



STEP 12

Remove the screw securing the stock intake box to the vehicle.

Tools Required: Socket wrench, 10mm Socket

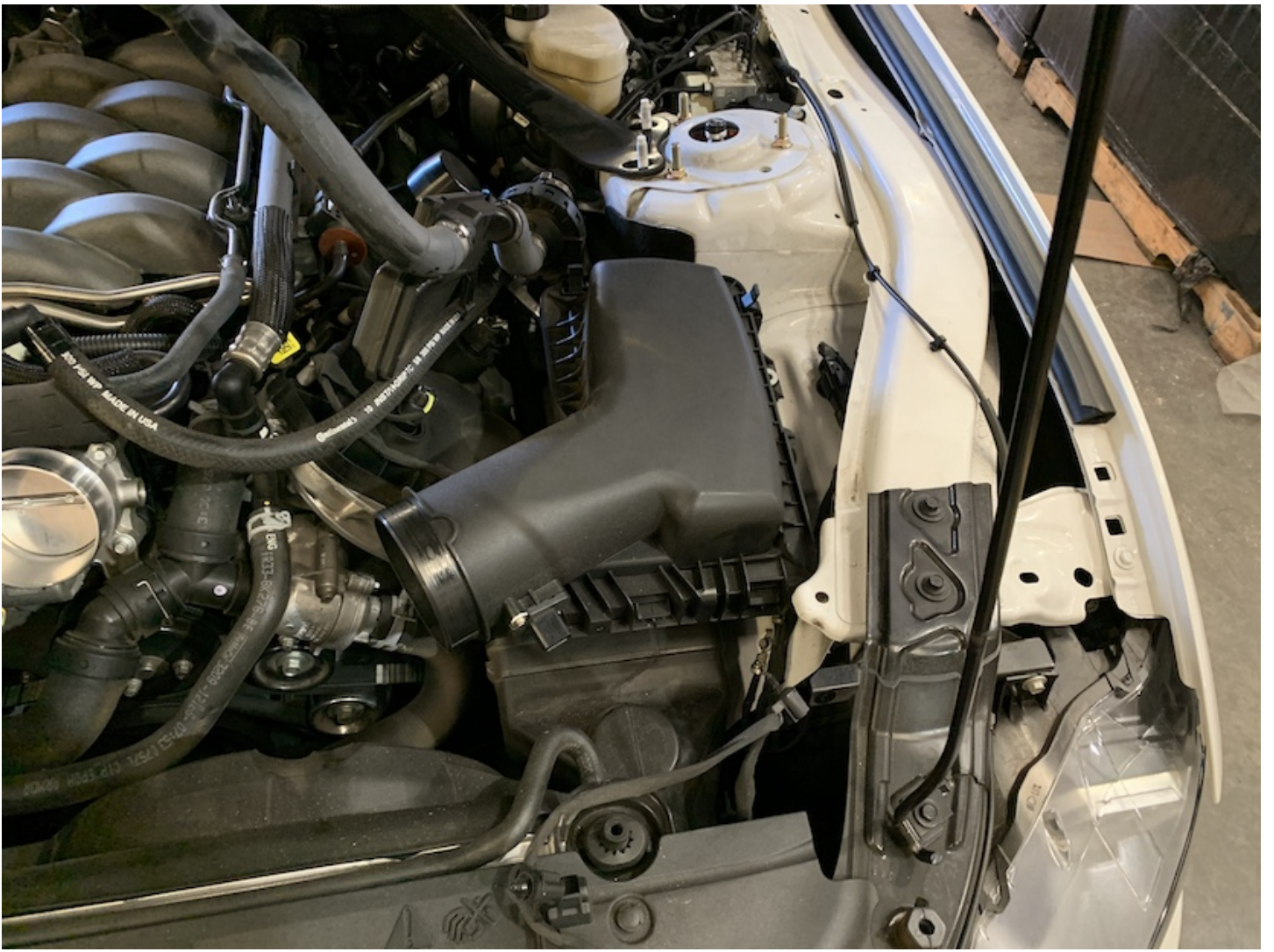

STEP 13

Remove the stock intake box from the vehicle by lifting it up and out.

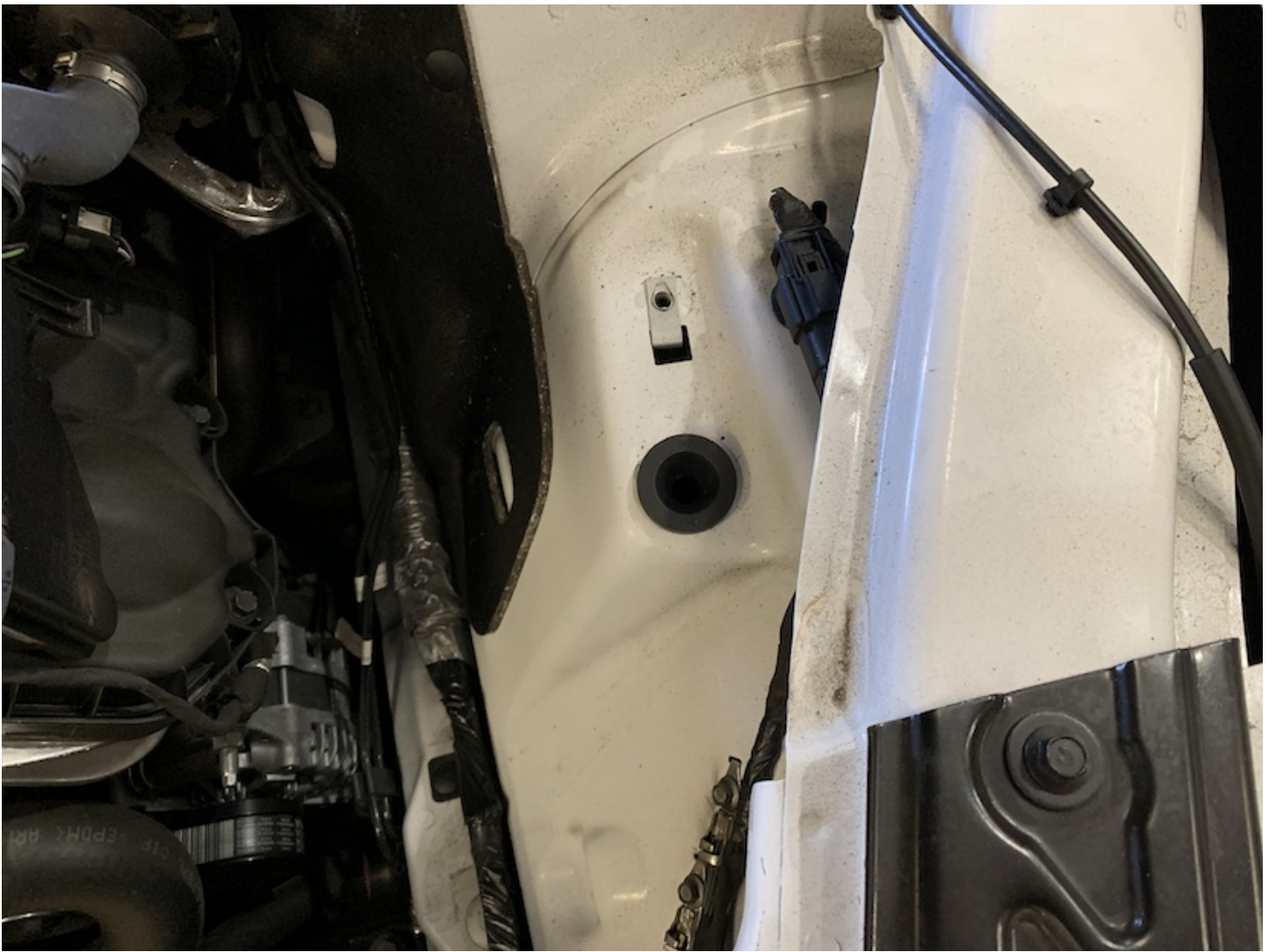

STEP 14

Verify that the grommet pictured did not come out of its hole on the vehicle with the stock intake box. If it did, remove it from the intake box and return it to its hole on the vehicle.

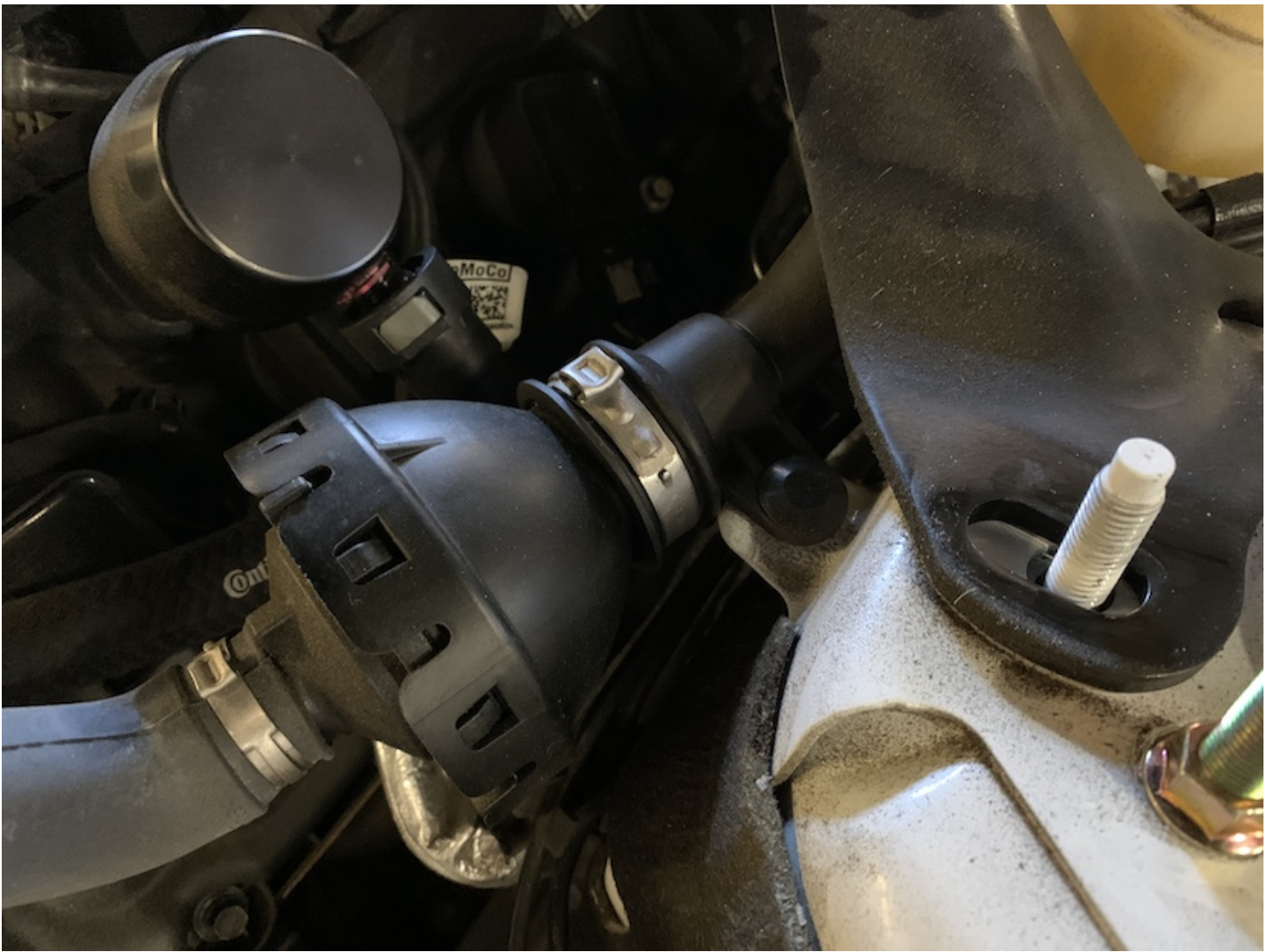

STEP 15

Cut off the crimp-on clamp shown on the cabin sound tube. After it has been cut off, remove from the vehicle, the section of the tube which used to connect the stock intake tube to the area where the clamp was found.

Tools Required: Bolt Cutters



STEP 15
IMAGE 2



STEP 16

Install the S&B block off plug (18) into the rubber cup that makes up the end of the remaining cabin sound tube. Use the #24 hose clamp (19) to secure the plug within the rubber cup. The function of these last steps was to delete the cabin sound tube from the vehicle in the easiest way possible. Doing this provides for a more genuine intake sound that is not artificially boosted or pumped into the cabin. The removal of the cabin sound tube may not be skipped and is necessary in the installation of the S&B intake kit.

Tools Required: Socket wrench, 5/16" Socket



STEP 17

Install the rubber grommet (2) and shoulder washer (3) into the hole found on the JLT intake box (11).

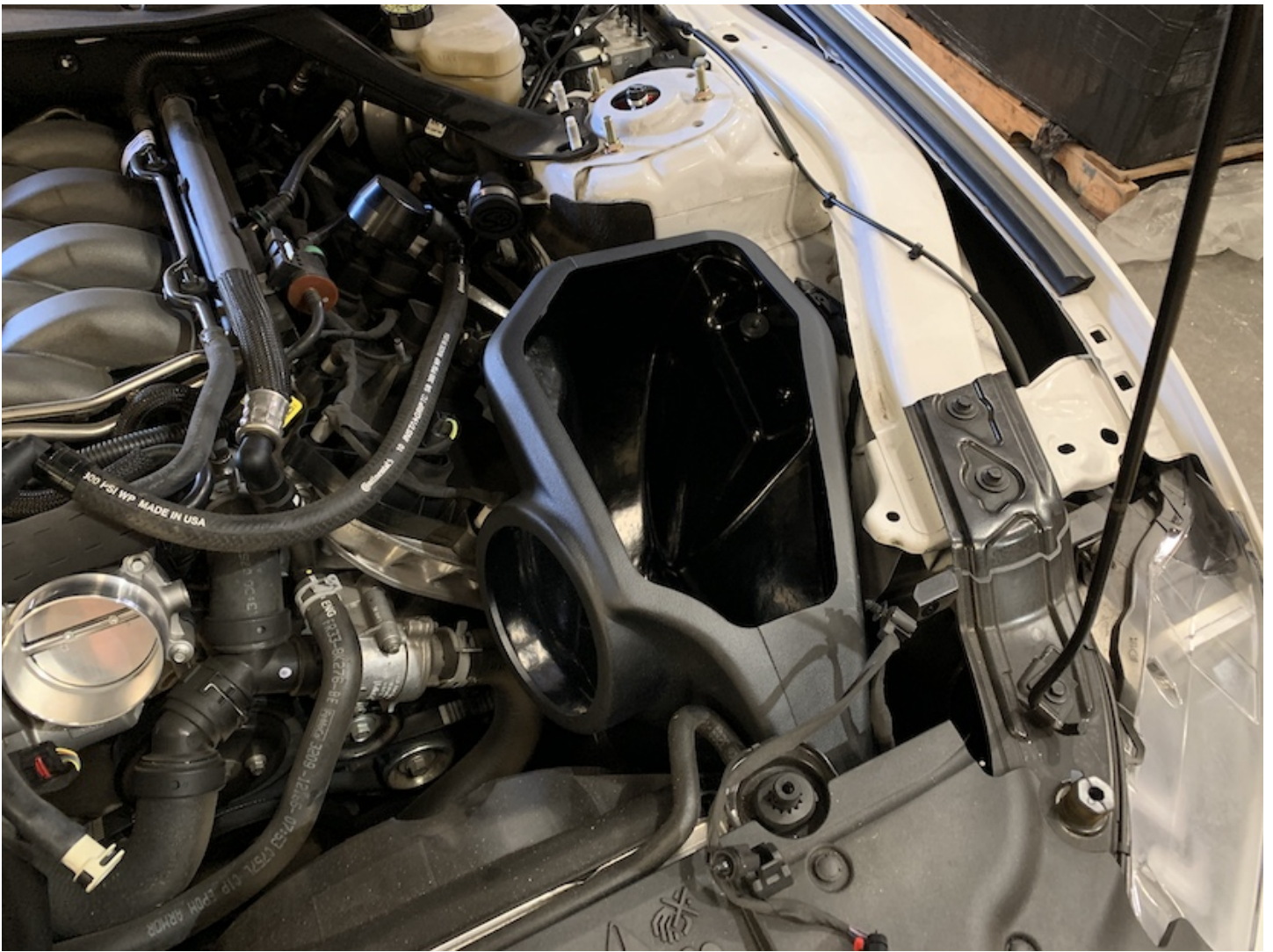

STEP 18

Place the JLT intake box into the vehicle, ensuring that the front inlet completely encompasses the front grill air connection and that the prong found on the box seats snugly into the grommet shown in step 14.



STEP 19

Secure the JLT intake box to the vehicle by reinstalling the screw removed in step 12.

Tools Required: Socket wrench, 10mm Socket

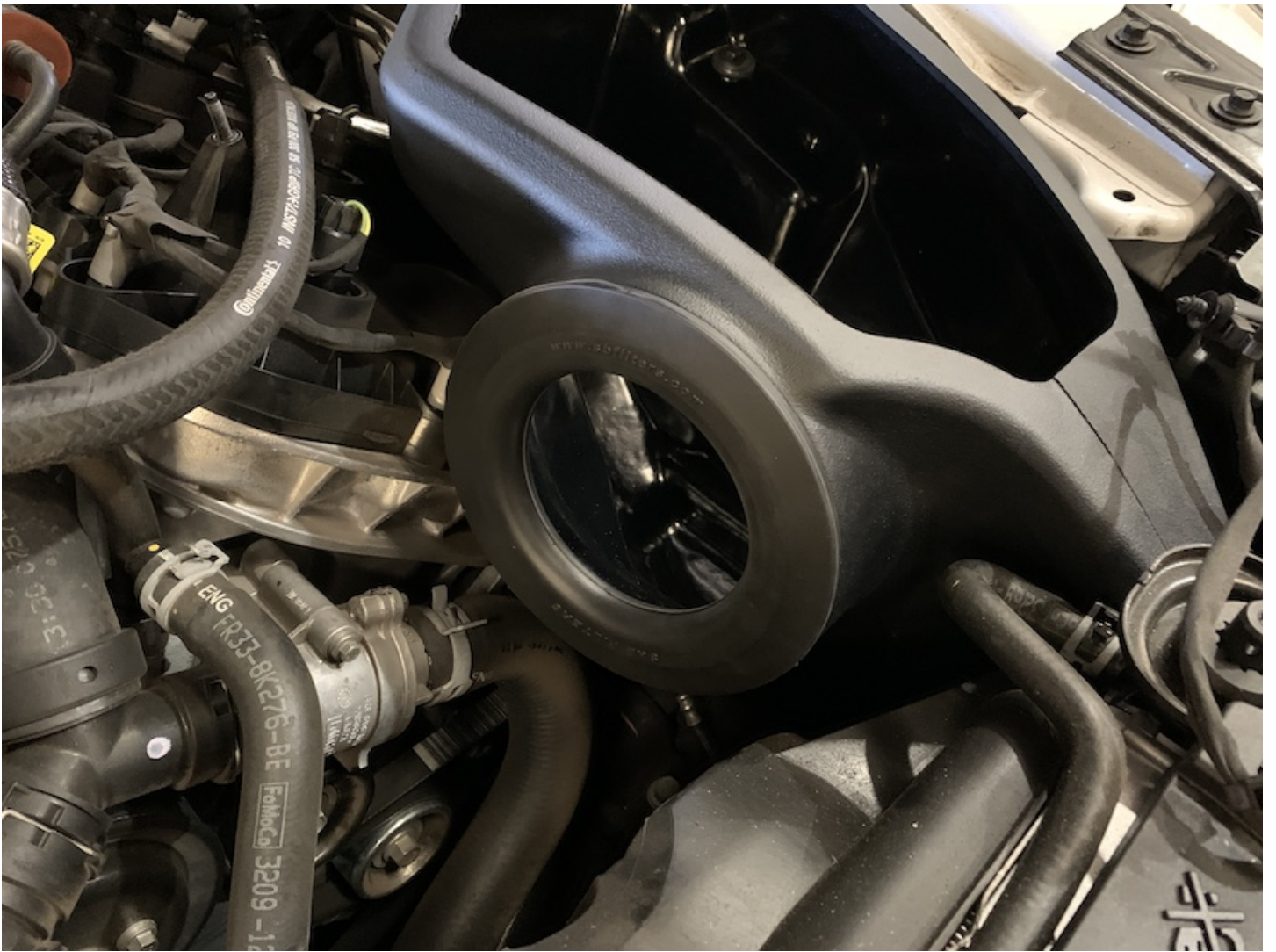

STEP 20

Install the tube seal (1) on the JLT intake box.



STEP 21

Remove the MAF sensor from the stock intake box.

Tools Required: T20 Torx.



STEP 22

PART A

Prepare the JLT intake tube for installation by connecting all of the components shown in the picture to the intake tube. These components include the $\frac{1}{4}$ NPT quick connect (4), $\frac{3}{8}$ NPT quick connect (5), silicone coupler (8), MAF sensor, MAF sensor pad (6) and MAF sensor gasket (7). Hand tighten quick connect fittings and then use a crescent wrench and tighten it another one to two complete turns. Secure the silicone coupler to the tube using the #64 hose clamp (14) and tighten the #60 hose clamp (15) around the other end of the coupler so that the hose clamp remains somewhat loose but doesn't fall off.

Tools Required: Socket wrench, 5/16" Socket, Adjustable wrench

IMPORTANT: Do not over tighten the Quick Connect Fittings as they can break or the threaded inserts may strip!



STEP 22

PART B

Part B

Attach the MAF sensor to the JLT intake tube using the provided MAF gasket, MAF adapter pad and philips head screws (13). The MAF gasket should be contacting the tube with the adapter, pad followed by the MAF sensor, sitting on top of it.

Tools Required: Philip's Head Screwdriver



STEP 23

Install the JLT intake tube into the vehicle in the position shown. Tighten the #60 hose clamp, securing the JLT intake tube to the engine throttle body.

Tools Required: Socket wrench, 5/16" Socket.

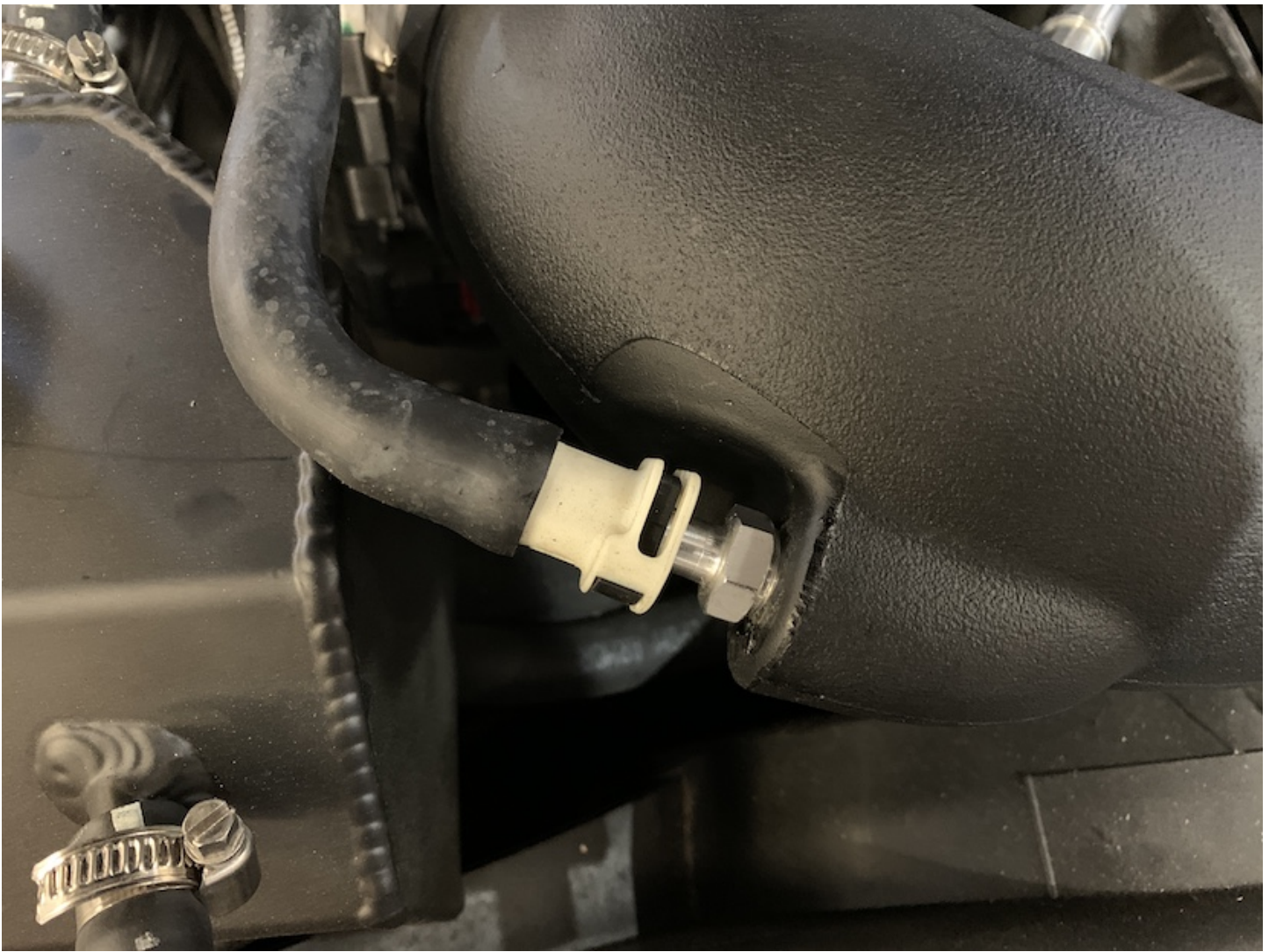

STEP 24

Connect the vacuum hose to the JLT intake tube, pressing it onto the 1/4 NPT quick connect.

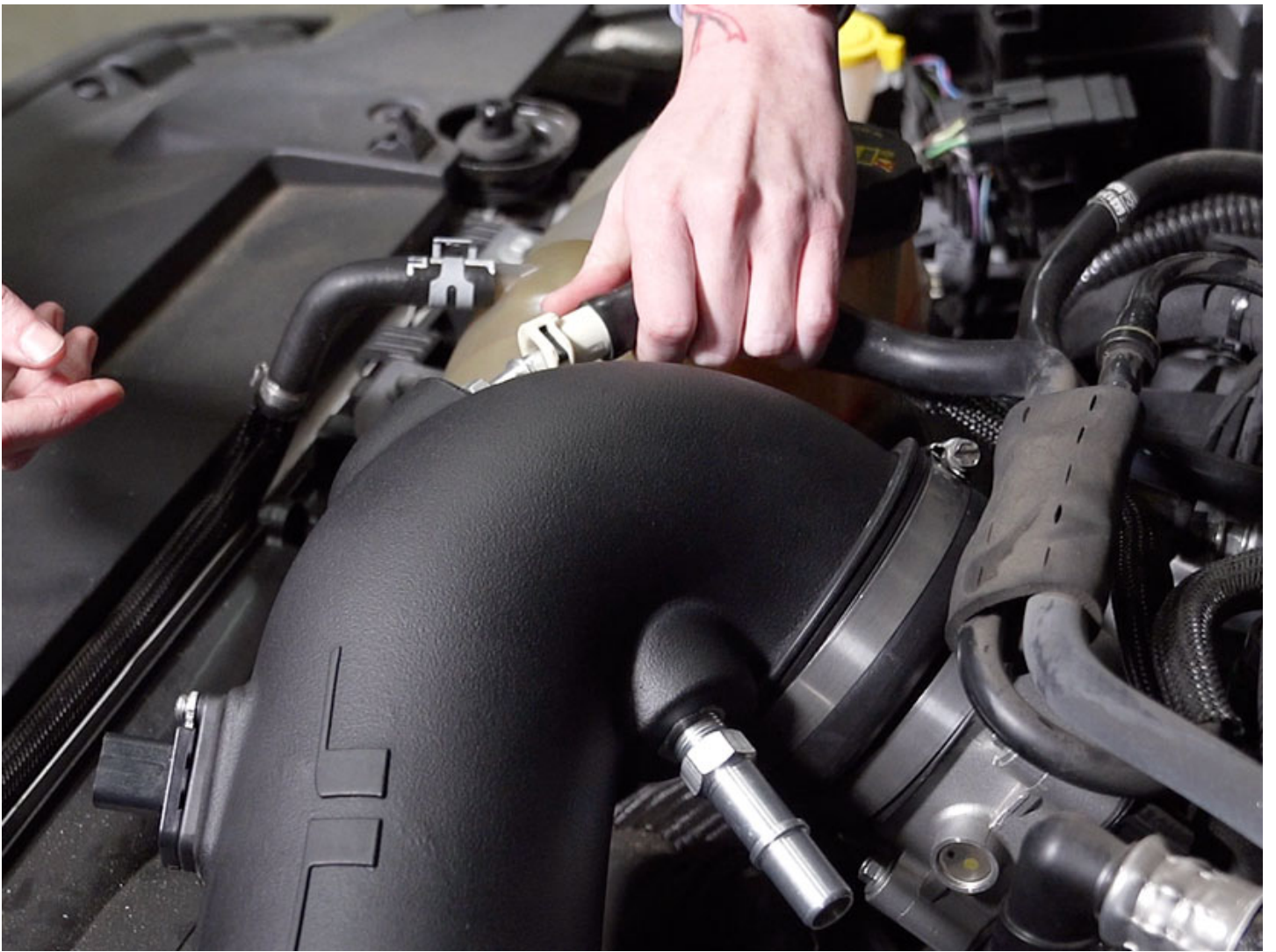

STEP 25

Connect the PCV hose to the JLT intake tube, pressing it onto the $\frac{3}{8}$ NPT quick connect.



STEP 26

Reconnect the MAF sensor harness to the MAF sensor by pressing forward on the red locking tab.

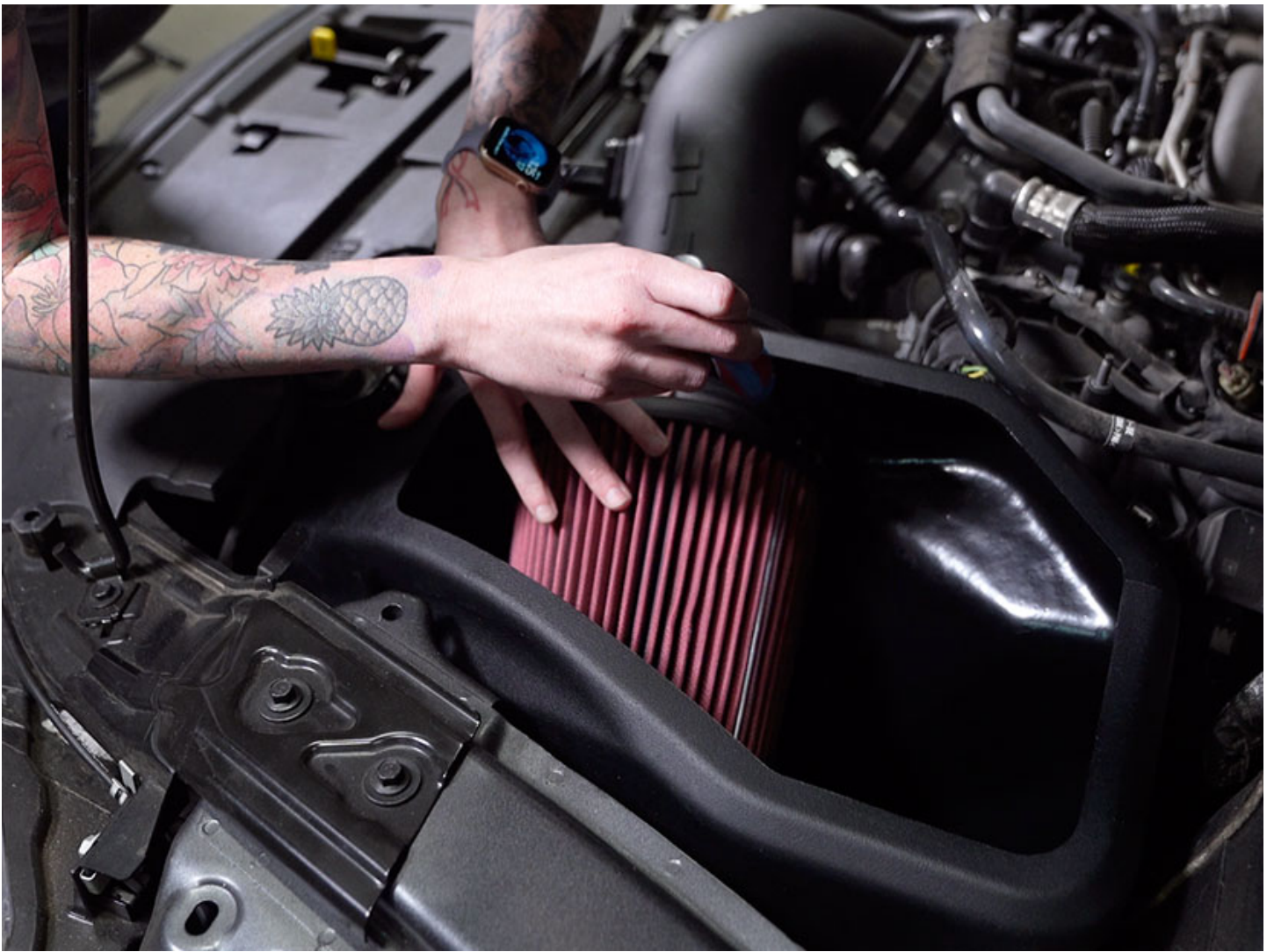

STEP 27

Connect the filter (10) to the JLT intake tube by placing it inside of the airbox and sliding the flange over the end of the tube. Secure the filter to the tube by tightening the #80 hose clamp (17).

Tools Required: Socket wrench, 5/16" Socket.

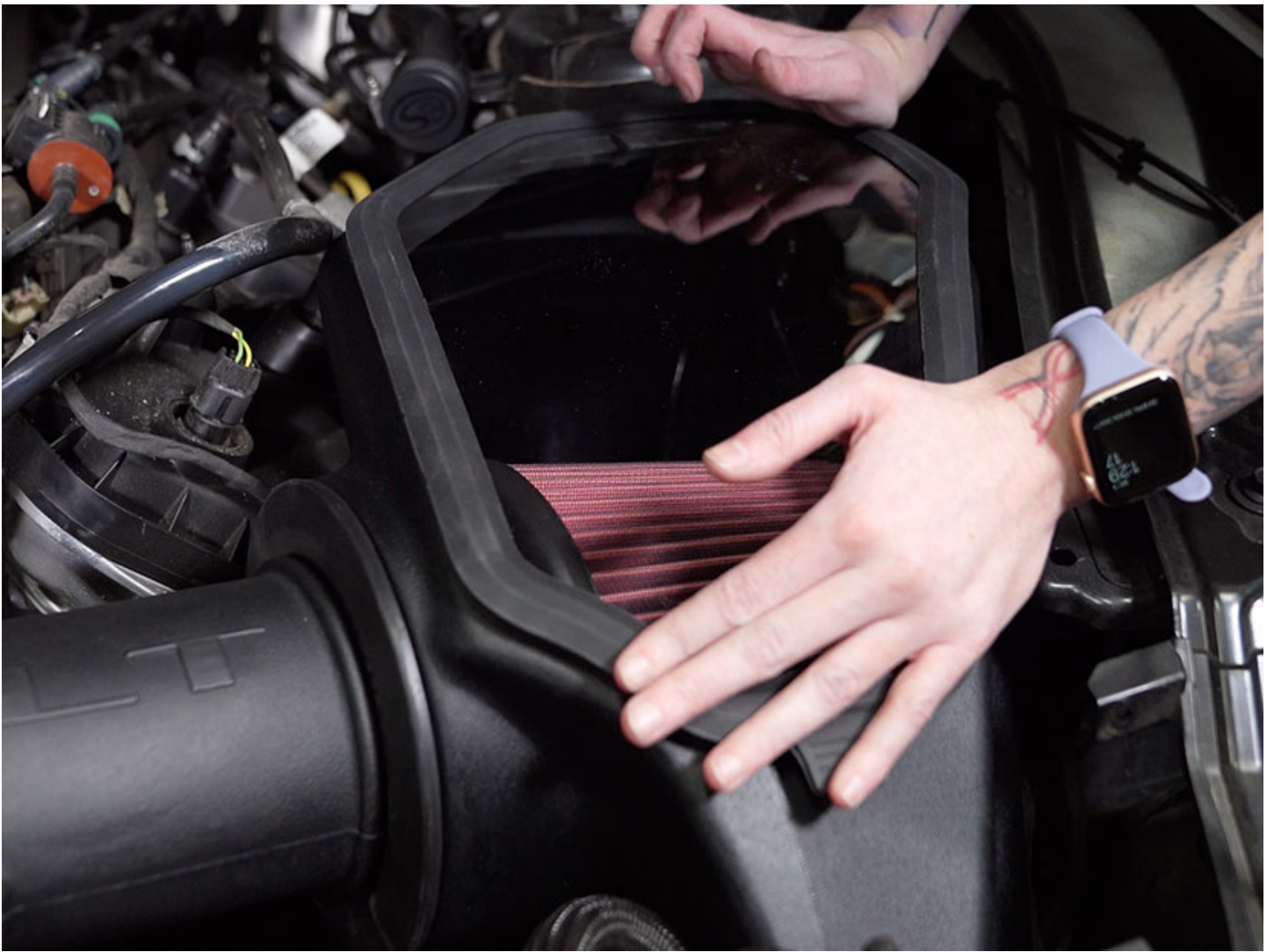

STEP 28

Install the lid seal (9) onto the lid (16) by stretching it around the perimeter of the lid. Snap the lid onto the top of the airbox by pressing down on all of the edges, ensuring that all edges of the lid are securely and completely snapped into place.



STEP 29

Reinstall the engine cover by pressing it down into the correct position on top of the engine and reinstalling the nuts removed in step 5. Replace the circular covers, concealing the installed nuts.

Tools Required: Socket wrench, 10mm Socket, Socket extension.



STEP 30

Reinstall the strut tower brace and the four screws removed in step 4.

Tools Required: Socket wrench, 15mm Socket.

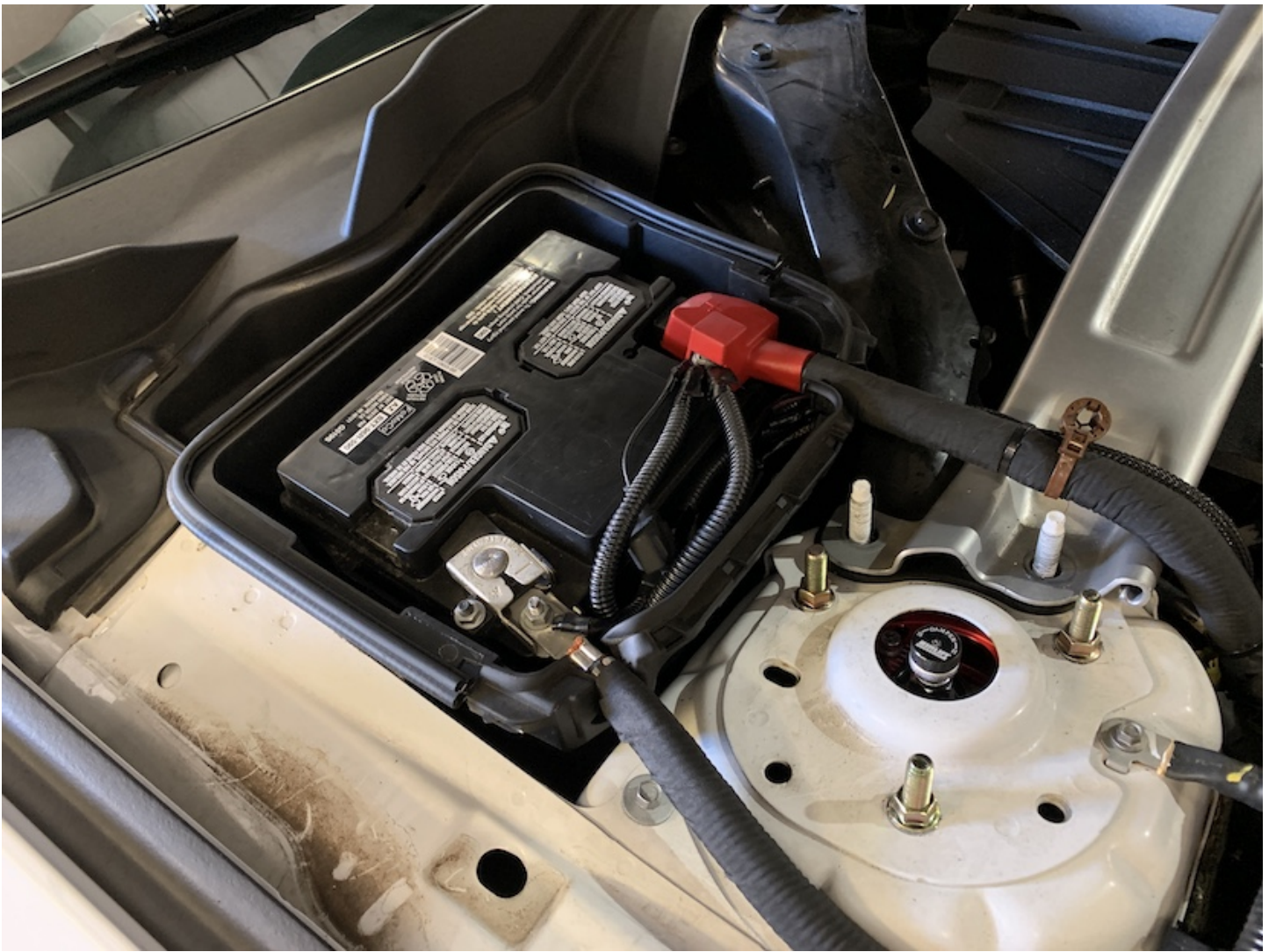

STEP 31

Reconnect the positive terminal on the battery.

Tools Required: Socket wrench, 10mm Socket.



STEP 32

Replace the battery cover by reinstalling the twisting panel screws.



STEP 33

Reconnect the positive battery harness to the threaded stud by pressing down on top of the brown zip tie connector.

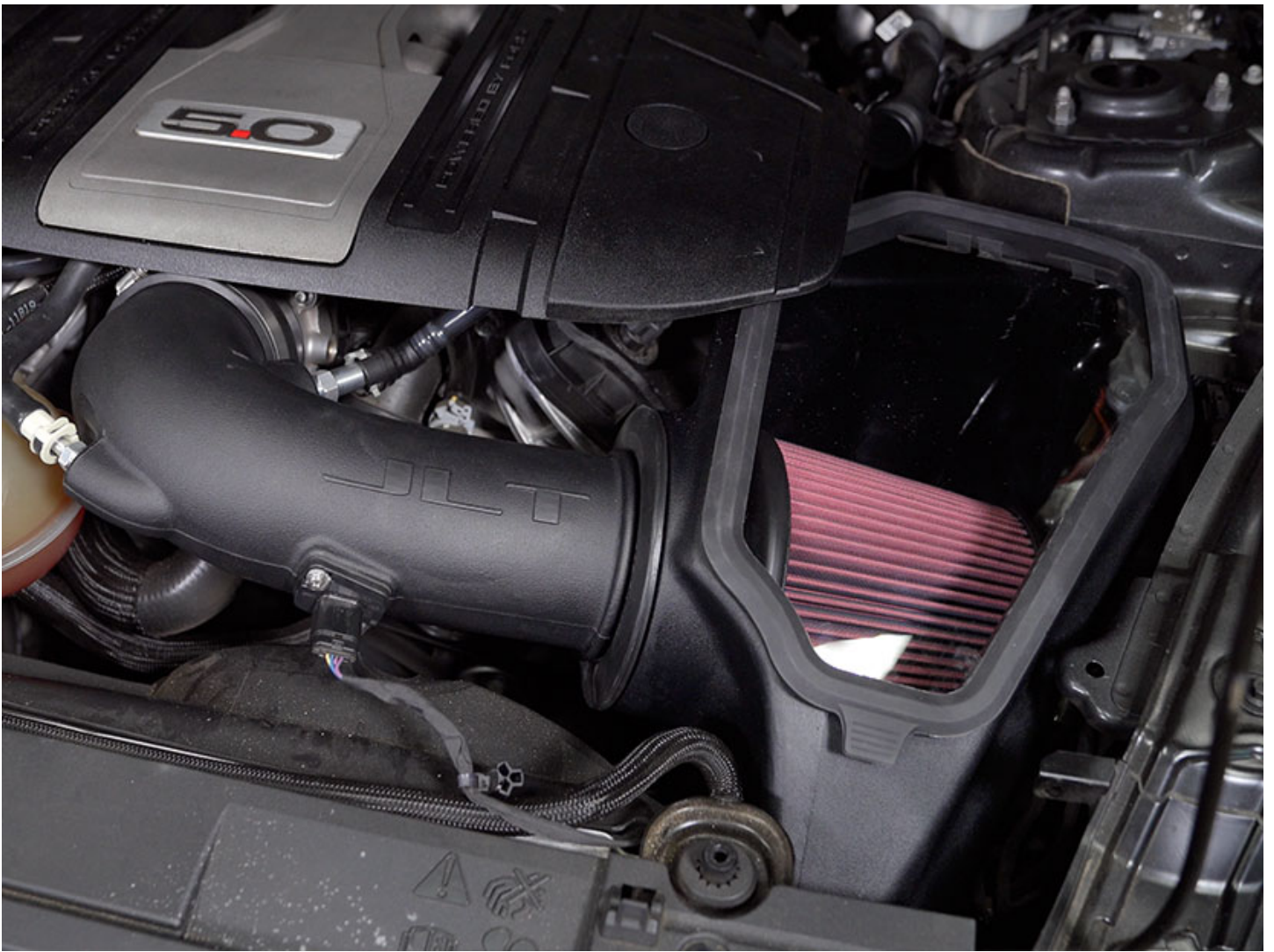

STEP 34

Inspect your installation, make sure the kit is properly positioned and all fasteners are secured. JLT recommends keeping all stock parts in case you would ever need to reinstall the stock intake. Affix the ID label near the intake kit. **The installation is now complete.**